

MACTek[®] Corporation
Bullet[™] WirelessHART[®] Adapter – Model 110100
User Manual



WirelessHART

MACTek[®]
Measurement & Control Technologies

LIMITED WARRANTY

Bullet™ WirelessHart® Adapter

MACTek® Corporation warrants this interface and all its component against defects in materials or workmanship for a period of one year from the date of purchase. This warranty only extends to the original consumer of this product.

If the Interface or a component does not function because of defects in material or workmanship during the warranty period, **MACTek** will either repair the defective product or replace it with a new or remanufactured functionally equivalent product of equal value. The original consumer must send proof of purchase along with the defective product as provided below. To obtain service under this warranty, first call the **MACTek** Support Center to obtain a Return Merchandise Authorization (RMA) number from **MACTek**; then deliver the product, shipment pre-paid, to **MACTek** addressed as follows:

MACTek Engineering Dept.
Attn: RMA # _____
2112 Case Parkway South #1
Twinsburg, OH 44087
USA

Call the **MACTek** Support Center at (330) 487-5477 to obtain an RMA number, or for further product or service information under this warranty.

MACTek has no obligation to repair or replace any defective product that has been subject to misuse, neglect, accident, or abuse, or subject to alteration or repair by persons other than **MACTek** or its authorized repair agents. This warranty does not cover normal wear and tear.

REPAIR OR REPLACEMENT AS PROVIDED UNDER THIS WARRANTY IS THE SOLE AND EXCLUSIVE REMEDY OF THE CONSUMER. **MACTek** SHALL NOT BE LIABLE FOR ANY INCIDENTAL OR CONSEQUENTIAL DAMAGES OR FOR BREACH OF ANY EXPRESS OR IMPLIED WARRANTY ON THIS PRODUCT. EXCEPT TO THE EXTENT PROHIBITED BY APPLICABLE LAW, **MACTek** SPECIFICALLY DISCLAIMS ANY IMPLIED WARRANTY OF MERCHANTABILITY OR FITNESS FOR A PARTICULAR PURPOSE.

Some state or countries do not allow limitations on how long an implied warranty lasts, so the above limitation may not apply to you. In addition, some states or countries do not allow the exclusion or limitation of incidental or consequential damages, so the above limitation may not apply to you.

This warranty gives you specific legal rights, you may also have other rights which vary from state to state and country to country.

No terms in any purchase order or other sales agreement shall alter or replace the terms contained in this Limited Warranty.

WirelessHART® and *HART®* are registered trademarks of the HART Communication Foundation.
MACTek® is a registered trademark and *Bullet™* is a trademark of *MACTek Corp*

Table of Contents

1. OVERVIEW	5
Basic Operation.....	6
Typical Usage.....	6
Power	7
<i>Loop Powered Mode</i>	7
<i>Direct Powered Mode</i>	8
<i>External Power Source Mode</i>	8
2. CONFIGURATION	9
Bench Top Configuration	9
Quick Setup.....	9
<i>HART Dynamic Variables</i>	11
<i>Configure Power Mode (method)</i>	11
<i>Adapter Power</i>	11
<i>Join Device to Network (method)</i>	13
<i>Network ID</i>	13
<i>Join Key</i>	13
<i>HART Polling Address</i>	14
<i>HART Master Mode</i>	14
<i>HART Retry Count</i>	15
<i>HART Number of Response Preambles</i>	15
<i>Write Protect</i>	15
<i>Sub-Device Time Synchronization</i>	15
<i>Sub-Device Scan on Power-up</i>	15
<i>Scan Start Address</i>	16
<i>Scan Stop Address</i>	16
<i>Scan for Sub-Devices (method)</i>	16
<i>Automatic Burst Mode Configuration</i>	16
<i>Factory Reset</i>	16
Alerts	18
<i>ALERT – Direct Power Out of Range</i>	18
<i>ALERT – Loop Power Out of Range</i>	19
<i>ALERT – Temperature Out of Range</i>	19
<i>ALERT – Power Mode Misconfigured</i>	19
<i>ALERT – Watchdog Reset</i>	20
<i>ALERT – Stack Overflow</i>	20
<i>ALERT – Duplicate HART Master Detected</i>	20
<i>ALERT – HART Devices Count Exceeded</i>	21
<i>ALERT – HART Sub-Device Lost</i>	21
<i>ALERT – Burst Packets are Being Dropped</i>	21
<i>ALERT – Field Device Power Control</i>	22
<i>ALERT – Wireless Capacity Denied</i>	22
<i>ALERT – Burst Message Configuration Issue</i>	23
<i>ALERT – Wired Device in Burst Mode</i>	23
<i>ALERT – Bullet Failed to Join the Network</i>	23
<i>ALERT – Radio Malfunction</i>	24
<i>ALERT – Variable Simulation</i>	24
HART DD Menu Tree.....	25
3. INSTALLATION.....	26
Antenna Positioning	26
Typical Installation.....	26
<i>Bullet as a Standalone WirelessHART Router</i>	27
<i>Bullet with a 4-20mA Analog Transmitter (non-HART)</i>	27
<i>Bullet with a 4-20mA HART Transmitter</i>	27
FIGURE 1: Configuration #1	28
FIGURE 2: Configuration #2	28
<i>Bullet with HART Devices in Multi-Drop Mode</i>	28
<i>Bullet with a 4-20mA Transmitter with Battery Powered Operation</i>	29
<i>Bullet installation to Field Device</i>	29

- 4. COMMISSIONING 30**
- 5. TROUBLESHOOTING 31**
 - Does Not Detect Wired-HART Sub-Devices 31
 - Cannot Connect to the WirelessHART Network 31
 - Resetting the Bullet 31
 - Soft Reset – Via DD* 31
 - Soft Reset – Via Power connections* 31
 - Hard Reset* 31
- 6. CERTIFICATES AND APPROVALS 32**
 - Telecommunication Compliance 32
 - FCC and IC 32
 - European Union Directives 32

1. Overview

The Bullet enables existing wired HART field devices to communicate with host applications by means of WirelessHART™ technology. The Bullet is installed permanently by screwing it directly into an available spare port of HART field device, or using a short, right angle elbow conduit. Other installation options are possible anywhere on the loop using a junction box or T-fitting. A wired HART field device retrofitted with a Bullet communicates its PV over the existing wiring to DCS and simultaneously communicates diagnostic and alarm data over the WirelessHART network to process management, asset management and engineering applications. The Bullet has options for power scavenging or local/direct power. The Bullet when powered by the current loop saves users the long term cost of battery maintenance, replacement and disposal programs. The Bullet Local/Direct power option can be used when the field device is powered either by a power supply or an external battery/solar system. In the case of external battery power, the Bullet provides battery power management by cycling the field device power and taking periodic readings.

Typical Use Cases

- Upgrade legacy wired HART analog only field devices with WirelessHART communication capability to enable 24/7 monitoring of alarms and diagnostic information
- 1-Port WA is the preferred housing for explosion proof conduit applications
- Low cost / low risk means to test and evaluate WirelessHART networks in a plant
- Substitute for multiplexers or legacy DCS upgrade to HART enabled IO.
- External Battery powered wireless remote I/O data collection

Features

- HART 7.1 Registered with HCF = fully HART compliant for communication reliability when the WirelessHART test suite is available
- Loop powered – no batteries or other power sources required
- Connects directly to HART field device and optionally anywhere on the 4-20 mA control loop
- MACTek patent pending StepVolt™ technology sets insertion voltage in steps from 1 to 2.5 volts to optimize trade off between available loop power and Wireless communication bandwidth
- Direct Power option when local DC power is available: system power, external battery/solar system
 - Internal 250 ohm loop current sense resistor provided, configurable by WirelessHART command.
 - In Direct Power mode, can switch field device on/off to take periodic readings to save power.
- Multidrop support for up to 8 devices (maximum number depends on installation)
- 235 meters open air range (nominal)

Basic Operation

The Bullet WirelessHART Adapter allows legacy wired-HART devices to be connected to a WirelessHART network. This allows remote access to diagnostic data, digital process variables, and alarm data stored inside HART devices.

The Bullet has both a wireless interface to communicate with the WirelessHART network and a wired-HART interface which is connected to a traditional 4-20mA current loop. The Bullet communicates as a wired-HART master to connected HART devices on the loop, and can transmit and receive HART data from these connected HART devices to the WirelessHART network. The Bullet also supports being configured like a wired-HART slave device, so traditional HART configuration tools (such as HART Field Communicators and PCs with HART modems) can be used to configure the Bullet.

In WirelessHART terminology, any wired-HART devices that can be communicated with from a WirelessHART Adapter is known as a sub-device. A single Bullet WirelessHART Adapter can support up to eight (8) wired-HART sub-devices connected to it. The WirelessHART Gateway maintains a list of all of the devices in the WirelessHART network, including sub-devices connected to WirelessHART Adapters. Host applications that communicate with the WirelessHART gateway can communicate directly with the wired-HART sub-device, and the WirelessHART gateway and WirelessHART Adapter will transparently handle the message translation.

WirelessHART supports publishing of data from devices to the WirelessHART Gateway on a periodic basis. This is called “burst mode” in HART terms, but is much more advanced than the “burst mode” traditionally supported by HART devices. Data can be burst based on an update time or when the specified process value causes a trigger that has been configured to trip - such as when the process value rises above a certain point.

When the Bullet is configured in burst mode, it supports all of these advanced modes on behalf of any wired-HART sub-devices that are connected. Burst mode is also very useful to publish device status data (such as malfunctions or alarms) to the Gateway on a periodic basis or immediately when a critical event occurs.

Typical Usage

In most network configurations, the Bullet will be used in conjunction with a wired-HART sub-device and will be configured to publish process data and device status data from the sub-device to the WirelessHART network on a periodic basis (such as every 8 seconds or every minute, etc).

The Bullet adds several features to make this typical usage mode very easy to configure, such as the Automatic Sub-Device detection and Automatic Burst mode configuration.

Power

The Bullet WirelessHART Adapter has been designed to be extremely power efficient and flexible to allow for a wide variety of installation options.

Loop Powered Mode

The Bullet can be wired in series with devices on a 4-20mA loop and be powered from the loop. The Bullet utilizes MACTek's patent pending **StepVolt™** technology, to allow the user to set this insertion voltage drop between 1.0 – 2.5 Volts, in 0.5 Volt increments.

StepVolt™ allows users to select the best insertion voltage drop for their application. The higher the voltage drop setting used, the more WirelessHART messages the Bullet will be able to transmit and receive.

In applications where there is very little voltage overhead in the loop, such as transmitters on very long cable runs or with IS barriers, StepVolt™ allows the selection of a low insertion voltage drop. However in a number of applications there is plenty of voltage overhead on the loop to allow for a high voltage insertion drop from the Bullet.

A concern with a loop powered WirelessHART Adapter is being able to operate under worst case conditions since very little power is available to be used by the Adapter at low loop current conditions. The Bullet is designed to operate at the worst case operating conditions at all power settings and will respond to Wired or WirelessHART commands.

The Bullet will operate as specified with reliable communications even under the following conditions:

- Loop current of 3.2mA and 1.0V insertion voltage drop
- Temperature Extremes (-40C to +85C)
- Worst Case wired-HART communication on the loop. Constant wired-HART communication addressed to the Adapter and the Adapter responding to every command.
- Every WirelessHART timeslot filled and transmitting

Note: On power-up, the voltage drop will be set to 1.0V until the Bullet has finished initialization. At this point, it will change the voltage drop to the value specified.

NOTE: The Bullet cannot control the loop current, if connected in loop-powered mode there must be something controlling the loop current, such as a 4-20mA transmitter.

StepVolt™ Benefits

The benefit to using a high StepVolt™ setting is that the Bullet will be able to support a much higher amount of WirelessHART packets per second. Even if the particular device attached to the Bullet is configured for a very low update rate, being able to support a high amount of WirelessHART packets per second helps the overall WirelessHART network operation.

WirelessHART is a mesh network – each node in the network will route messages on behalf of other nodes in the network. This is done to expand the overall range of the network and also for the data reliability of the network by forming multiple redundant paths. By setting the Bullet to a high StepVolt™ setting, more WirelessHART packets can be routed through the Bullet for other nodes in the network.

Another consideration from a WirelessHART network standpoint is that many devices in a WirelessHART network are battery powered and all wireless transmissions performed by these devices impact their battery life. The more WirelessHART devices that a battery powered node has to route messages for, the shorter its overall battery life is.

The Bullet is different – since it is loop powered it can support wireless messages indefinitely without any concerns of battery life. By placing MACTek Bullet's at key locations in a WirelessHART network, such as places that route messages for other WirelessHART nodes, this routing function can be offloaded from battery powered nodes to the Bullet and help to preserve their battery life of the battery powered nodes.

StepVolt Setting	WirelessHART Packets per Second
1.0 V	5.79
1.5 V	12.65
2.0V	19.66
2.5V	26.66

*Note: The value shown in WirelessHART Packets per second column is the value reported back in HART Command 777. **These values are preliminary and subject to change.***

Recommendation: Plan on using the highest StepVolt™ setting possible to help the overall WirelessHART network performance.

Direct Powered Mode

In direct powered mode, the Bullet can be powered by an external DC supply. The DIRECT POWER connections are DIRECT POWER, black lead wire, to the positive potential and the RETURN, white lead wire, to the negative terminal of the external DC source. The voltage range of this input is 7VDC to 32VDC.

External Power Source Mode

The Bullet can be powered by an external DC power source such as; battery, solar panel and control power to the Field device.

2. Configuration

This section contains information on configuration that should be performed prior to installation of the Bullet in the field.

Initial configuration is performed through the use of a HART Device Descriptor (DD) for the Bullet over the wired-HART connection. Once connected to the WirelessHART network, configuration changes can be made using the DD over either the wired-HART interface or the WirelessHART interface.

Bench Top Configuration

Power the Bullet. This can be performed by connecting the bench power supply positive terminal to the “Direct Power” input wire and the power supply negative terminal to the “Return” wire.

Connect HART communicator or HART modem to the Bullet. Connect one lead of the HART modem to the “Return” wire of the Bullet and the other lead of the HART modem to the “HART” wire of the Bullet. The HART signal connection is polarity independent.

NOTE: By default, the Bullet is at HART polling address 15.

NOTE: By default, all WirelessHART Adapters are configured as a primary HART master. The HART communicator used to configure the Bullet should be configured in Secondary HART master mode.

Wire Color	Description
Green / Yellow	Internal Earth Ground
Black	Direct Power
Red	Loop Power
White	Return
Yellow	HART
Ground Screw	External Earth Ground

Quick Setup

Connect into the device using the DD.

Set the HART Tags for the Bullet:

1. From the Main DD screen, select Configure... (In Simatic PDM, select Configure... from the Device menu at the top of the screen).
2. Select Manual Setup... Bullet Information...
3. Enter in the HART Tag
4. Enter in the HART Long Tag
5. Transfer the updated information to the Bullet by clicking on the “Send” or “Transfer” button

Set the Power Configuration for the Bullet:

1. From the Main DD screen, select Configure... (In Simatic PDM, select Configure... from the Device menu at the top of the screen).
2. Select Guided Setup...
3. Select Configure Power Mode...
4. Follow the on screen instructions and select the proper power configuration for the application.

Configure Burst settings

1. From the Main DD screen, select Configure... (In Simatic PDM, select Configure... from the Device menu at the top of the screen).
2. Select Manual Setup... Burst Settings...
3. Set the Automatic Burst Mode to the desired update rate (recommended) or set this to disabled.
4. If not using the Automatic Burst Mode, manually set the burst mode configuration for each Burst Message. *Note: Sub-devices must be detected before configuring the manual Burst Mode configuration.*
5. Transfer the updated information to the Bullet by clicking on the “Send” or “Transfer” button

Configure WirelessHART Network settings

1. From the Main DD screen, select Configure... (In Simatic PDM, select Configure... from the Device menu at the top of the screen).
2. Select Guided Setup...
3. Select Join Device to Network...
4. Follow the on screen instructions and enter in the WirelessHART Network ID and join key
5. After accepting the settings, the Bullet will attempt to join the network

Monitoring WirelessHART Network join status

1. From the Main DD screen, select Service Tools... (In Simatic PDM, select Service Tools... from the Device menu at the top of the screen).
2. Select Communications... Wireless Status...
3. Monitor the progress of the WirelessHART join. If “Join Failed” under Join Status becomes set, check the Network ID and Join Key that were used to see that they are correct.

At this point, the Bullet is ready to be installed and commissioned in the field.

Detailed Settings

HART Dynamic Variables

The Bullet appears as a HART device on both the wired-HART and WirelessHART networks, and supports four HART dynamic variables. These can be read using standard HART commands and are displayed in the Bullet DD.

HART Variable	WirelessHART Packets per Second
Primary Variable (PV)	Loop Current (mA)
Secondary Variable (SV)	Direct Power Voltage (V)
Tertiary Variable (TV)	Internal Temperature (C)
Quaternary Variable (QV)	Storage Voltage (V) (Internal to the Bullet)

Configure Power Mode (method)

The Configure Power Mode DD Method guides the user through the selection of the proper power mode settings for their configuration.

Adapter Power

By Default, the Bullet is configured for loop powered operation with a 1.0V insertion voltage drop. Through the DD, the power setting can be changed to set the insertion voltage drop to 1.0V, 1.5V, 2.0V or 2.5V. The power mode setting can also be set to several different direct power modes.

Adapter Power Setting	WirelessHART Packets per Second
Loop Powered - 1.0 V	5.79
Loop Powered - 1.5 V	12.65
Loop Powered - 2.0V	19.66
Loop Powered - 2.5V	26.66
Direct Powered – Max Bandwidth	101.40
Direct Powered – Power Save	26.66

*Note: The value shown in WirelessHART Packets per second column is the value reported back in HART Command 777. **These values are preliminary and subject to change.***

Loop Powered

This allows for different StepVolt™ settings to be selected when operating in a loop powered mode.

Direct Powered – Max Bandwidth

This allows for the maximum WirelessHART bandwidth possible and assumes that the direct power source can supply maximum power.

Direct Powered – Power Save

This assumes that the direct power source is limited and will limit the amount of WirelessHART packets to a small amount to conserve power

Note: The Bullet will power up and begin to operate with any valid power installation, regardless of what the Adapter Power setting is configured as. This allows for the user to change this setting even if it is configured incorrectly, however any changes to this should be performed before the Bullet has joined the WirelessHART network. If this power setting set different than how the Bullet is actually powered (such as a Direct Powered setting is selected but the unit is actually loop powered), the system operation is not guaranteed and it is possible that the Bullet will reset due to insufficient power once connected to the WirelessHART network.

Note: The unit can be both Direct Powered and wired in series with the loop. When configured in any of the Direct Powered modes, there will be an insertion voltage drop of 1.0V if the Bullet is also wired in series with the loop.

Field Device Power Control

When used in a direct power configuration, the Bullet can activate a switchable terminating resistor between the HART and the RETURN signal wires. This can eliminate the need for an external terminating resistor in some installation and also allows for the field device power to be switchable and controlled automatically by the Bullet.

The parameter “Field Device Power Control” can be set to three different states: Off, On, or Switching.

Off: The Field Device Power Control switch is never connected

On: The Field Device Power Control switch is always connected

Switching: The Bullet will automatically control the operation of the Field Device Power Control switch.

Field Device Power Control – Switching Mode

When the Bullet is used in the “Field Device Power Control Switching” mode, the Bullet will control this switch to power on and off HART Field Devices as needed by the network operation. This is useful when running off a limited power source, such as an

external battery or solar cell, and can be used to power off the HART field devices between measurements.

When used in combination with Burst mode, the Bullet will schedule measurements from the HART devices connected, and will turn on the loop when a scheduled measurement is needed. After all the measurements have been read from the connected HART devices, the Bullet will power off the field devices by turning off the “Field Device Power Control” switch.

For this mode to work properly, the user needs to determine and configure the “Power On Time” parameter for the connected wired HART field devices.

Field Device Power On Time: The time in seconds that a HART field device needs to be powered on in order to obtain an accurate measurement.

Note: Improper selection of the “Power On Time” parameter can lead to a field device reporting measurements outside of the published tolerances for the device. Consult the field device documentation or contact the field device vendor to determine this information.

Field Device Idle Time: The time in seconds that the field device will remain powered after an unscheduled event. This event could be a HART query over the WirelessHART handheld or detection of another HART master trying to communicate (such as a wired HART handheld). This parameter prevents the Bullet from powering off a field device when some other master is attempting communication with the field device. This parameter can generally be left at the default of 60 seconds.

Field Device Estimate On Percentage: This is the estimated time that the field device will be powered during normal operation. This is a calculation based upon the Field Device Power On Time and the Burst mode settings of the Bullet. The lower this value is, the less amount of power will be used.

Join Device to Network (method)

The Join Device to Network DD Method guides the user through entering in the WirelessHART network ID and join key, and starting the WirelessHART join procedure.

Network ID

The Network ID is the ID of the WirelessHART Network to join.

Join Key

The Join Key is a 32 character hexadecimal password (broken into four 8 character blocks) which is used to get access to the WirelessHART network.

Radio Output Power

The transmit power of the Bullet's radio. Can be set to either 0dBm or +10dBm.

HART Polling Address

This is the HART polling address that is used to communicate to the Bullet on the wired-HART interface using a HART capable host (such as a HART communicator or PC with HART modem).

By Default, the Bullet is at HART polling address 15. Through the DD, the polling address can be set to any value between 0 and 63.

HART Master Mode

This is the HART Master mode used by the Bullet when it is communicating as a HART master with wired-HART devices.

By Default, the Bullet is configured as a HART primary master. Through the DD, the master mode can be changed to be either a HART secondary or primary master.

HART Retry Count

This is the amount of retries the Bullet will attempt when communicating as a HART master to wired-HART devices.

By Default, the Bullet is configured to use 3 retries. Through the DD, the retry count can be set to 2, 3, 4 or 5.

HART Number of Response Preambles

This is the amount of preambles the Bullet will use when responding to HART commands sent by a HART master (such as a HART communicator or PC with HART modem) on the wired-HART connection.

By Default, the Bullet is configured to use 5 preambles. Through the DD, the response preamble count can be set between 5 – 20 preambles.

Write Protect

This setting allows the configuration inside of the Bullet to be write protected. The write protect setting is controlled through the DD.

By Default, the Bullet is configured to have write protect disabled. Through the DD, the write protect setting can be enabled or disabled.

Sub-Device Time Synchronization

If a HART 7 or greater sub-device is detected and it supports a real-time clock, the Bullet can synchronize the sub-device time with the WirelessHART Network time if this setting is enabled. If the sub-device does not support a real-time clock, this setting has no effect. This synchronization will be performed when the Bullet joins the WirelessHART network and then once per day.

Sub-Device Scan on Power-up

When Sub-Device Scan on Power-up is enabled, the Bullet will scan the 4-20mA loop for attached HART devices on power-up or when the Bullet is reset. These will be added to the list of supported sub-devices for the Bullet and will be communicated with the WirelessHART gateway.

NOTE: The sub-device scan is only performed after a power-up or reset of the Bullet. If wired-HART devices are added to the loop after the Bullet is powered, execute the Scan for Sub-Devices method or reset the Bullet to detect them.

Within the DD, Automatic Sub-device detection can be enabled or disabled. It is highly recommended that this mode always be left **enabled**.

If this mode is disabled, the host must support scanning for sub-devices in order for any sub-device to be detected or you must manually execute the Scan for Sub-Devices method. The list of sub-devices is not retained through a power-cycle or reset of the Bullet, so the host would need to detect this and rescan for sub-devices.

NOTE: The Bullet can support a maximum of eight sub-devices. If more than eight wired-HART devices are detected, only the first eight devices will be used.

Scan Start Address

This is the first HART polling address that will be used when a scan for Sub-devices is performed.

Scan Stop Address

This is the last HART polling address that will be used when a scan for Sub-devices is performed.

Scan for Sub-Devices (method)

The Scan for Sub-Devices DD method will perform a scan for sub-devices connected to the Bullet, across the HART polling addresses defined.

This method allows for the existing sub-device list to be either retained or erased prior to the new scan.

Automatic Burst Mode Configuration

When Automatic Burst Mode Configuration is enabled, the Bullet will automatically configure burst messages for Bullet itself and all of the connected sub-devices.

The Automatic Burst Mode Configuration setting can be set from within the DD, and allows the user to select several different fixed update rates (1 second, 2 seconds, 4 seconds, 8 seconds, 16 seconds, 32 seconds, 1 minute, 2 minutes, 5 minutes, 10 minutes, 30 minutes, 60 minutes) at which all of the burst messages will be published to the WirelessHART gateway.

If this mode is disabled, burst mode can be configured manually using the DD.

NOTE: If the Automatic Burst Mode Configuration setting is set, this will override any manual configuration of the burst mode settings. If any manual burst mode settings are configured, Automatic Burst Mode will be automatically turned off.

Factory Reset

Executing the factory reset will reset the following Bullet parameters and then cause the Bullet to reset:

Bullet Parameter	Default Value
Adapter Power Mode	Loop Powered - 1.0 V
Field Device Power Control	Off
Field Device Turn On Time	10.0 seconds
Field Device Idle Time	60.0 seconds
WirelessHART Network ID	1229
WirelessHART Join Key	44555354 4E455457 4F524B53 524F434B (hex)
WirelessHART Join Mode	Don't Join
Radio Output Power	+10dBm
Over the Air Upgrade	Enabled
HART Master Mode	Primary Master
HART Retry Count	3
HART Polling Address	15
HART Sub-device Time Sync	Enabled
HART Scan On Power Up	Enabled
HART Polling Scan Start Address	0
HART Polling Scan Stop Address	15
HART Response Preambles	5
Write Protect	Off
HART Lock State	Cleared

Alerts

The Bullet will detect and log system events to alert the user when something has occurred that could effect system operation.

Note: All Alerts are also mapped into HART Command 48 status bits.

Active Alerts

The condition that caused the alert is still present. Active alerts cannot be cleared - corrective action must be taken to eliminate the alert, such as modifying some external source of the event (such as the power supply) or by changing an incorrect setting in the Bullet.

Alert History

The condition that cause the alert is no longer present, or the alert is a one time event. The start timestamp indicates when this alert first occurred and the stop timestamp indicates when the alert stopped (or the last time the alert was detected).

Clear Alert (method)

This will clear the current alert.

Clear All Alerts (method)

This will clear the entire alert history for the Bullet.

ALERT – Direct Power Out of Range

Description:

The Bullet is configured for Direct Power Mode and the voltage on the Direct Power input is outside of the allowable operating range for the Bullet.

Corrective Action:

Correct the Direct Power power supply.

Timestamps:

Start: Set when the alert is first detected.

Stop: Set when the alert state goes away.

ALERT – Loop Power Out of Range

Description:

The Bullet is configured for Loop Power Mode and the current on the loop power connection is outside of the allowable operating range for the Bullet.

Corrective Action:

Correct the loop power supply.

Timestamps:

Start: Set when the alert is first detected.

Stop: Set when the alert state goes away.

ALERT – Temperature Out of Range

Description:

The electronics temperature inside of the Bullet is outside of the allowable operating range for the Bullet.

Corrective Action:

Ensure that the Bullet is installed in an environment with its environmental operating range.

Timestamps:

Start: Set when the alert is first detected.

Stop: Set when the alert state goes away.

ALERT – Power Mode Misconfigured

Description:

The power mode detected on the inputs for the Bullet currently does not match the power mode configuration settings.

Corrective Action:

Check the Adapter Power mode setting to ensure it is the same as how the Bullet is wired.

Timestamps:

Start: Set when the alert is first detected.

Stop: Set when the alert state goes away.

ALERT – Watchdog Reset

Description:

The microprocessor inside of the Bullet has experienced a watchdog reset event.

Corrective Action:

Clear the alert – report the event to MACTek.

Timestamps:

Start: Set when the alert is first detected.

Stop: Not Used

ALERT – Stack Overflow

Description:

The microprocessor inside of the Bullet has experienced a stack overflow event.

Corrective Action:

Clear the alert – report the event to MACTek.

Timestamps:

Start: Set when the alert is first detected.

Stop: Not Used

ALERT – Duplicate HART Master Detected

Description:

A HART Master has been detected that is configured as the same Master type as the Bullet. This will prevent the Bullet from communicating with connected Sub-Devices while the other HART master is present.

Corrective Action:

If there is another HART Master present, ensure that it and the Bullet are configured for different HART Master types. When using a HART Handheld, ensure that it is not set for the same Master Type as the Bullet.

Timestamps:

Start: Set the first time the duplicate HART Master was detected.

Stop: Set the last time the duplicate HART Master was detected.

ALERT – HART Devices Count Exceeded

Description:

A HART Master has been detected that is configured as the same Master type as the Bullet. This will prevent the Bullet from communicating with connected Sub-Devices while the other HART master is present.

Corrective Action:

If there is another HART Master present, ensure that it and the Bullet are configured for different HART Master types. When using a HART Handheld, ensure that it is not set for the same Master Type as the Bullet.

Timestamps:

Start: Set the first time that too many HART devices were detected

Stop: Same as the start time

ALERT – HART Sub-Device Lost

Description:

A Sub-device connected to the Bullet has stopped communicating and has been dropped from the sub-device list.

Corrective Action:

If the Sub-device was removed intentionally, clear the alert. Else, check the connection / power to the sub-device and verify communications with a wired-HART handheld or PC.

Timestamps:

Start: Set when the sub-device was lost

Stop: Same as the start time

ALERT – Burst Packets are Being Dropped

Description:

One or more burst packets have been dropped from the Bullet to the WirelessHART Network.

Corrective Action:

Check to ensure that the WirelessHART Network has granted the requested bandwidth for the burst settings. If not, either adjust the WirelessHART network settings or adjust the burst times for the Bullet.

If the burst messages being dropped are for a wired Sub-device, ensure that there are no other HART masters on the connection, as these can cause burst message delays.

Timestamps:

Start: Set when the first HART Burst packet was dropped

Stop: Set when the last HART Burst packet was dropped

ALERT – Field Device Power Control

Description:

The field device power control mode is set to Switching, however the burst / event configuration will keep the device always powered on.

Corrective Action:

If the Field Device Power Control Mode – Switching is not required, change this option.

Else, reduce the burst times for the wired Sub-devices such that the system will switch the power to the devices. Check the “Field Device Estimate On Percentage” for an estimated duty cycle that the Field Devices will be powered on for. This alert will be set whenever this value is 100% and the Field Device Power Control Mode is set to Switching.

Timestamps:

Start: Set when the Field Device Power Control issue is first detected

Stop: Set when the Field Device Power control issue is corrected

ALERT – Wireless Capacity Denied

Description:

The WirelessHART network has denied a request for Wireless bandwidth.

Corrective Action:

Check the burst mode settings for the device and reduce the requested bandwidth.

Timestamps:

Start: Set when the WirelessHART Network first denies bandwidth

Stop: Set when the WirelessHART Network grants bandwidth

ALERT – Burst Message Configuration Issue

Description:

A burst message is configured to a command that is not supported by the selected Sub-device

Corrective Action:

Change the command number of the burst message to a command that is supported by the Sub-device.

Timestamps:

Start: Set when the configuration issue is first detected

Stop: Set when the configuration issue is corrected

ALERT – Wired Device in Burst Mode

Description:

A wired device is configured for wired burst mode, which may conflict with the Bullet burst settings.

Corrective Action:

Change the configuration of the wired device to not be in wired burst mode.

Timestamps:

Start: Set when the wired burst mode message is first detected

Stop: Set when the last wired burst mode message was detected

ALERT – Bullet Failed to Join the Network

Description:

The Bullet has failed to join the WirelessHART Network.

Corrective Action:

Check the Network ID and Join key set on both the Bullet and the WirelessHART Network.

Timestamps:

Start: Set when the WirelessHART Network Join procedure failed

Stop: Set when the WirelessHART Network Join procedure succeeds

ALERT – Radio Malfunction

Description:

The radio module inside the Bullet is malfunctioning.

Corrective Action:

Report this issue to MACTek.

Timestamps:

Start: Set when the radio malfunction was detected

Stop: Set when the radio malfunction clears

ALERT – Variable Simulation

Description:

One or more of the device variables are being simulated.

Corrective Action:

Check the simulation settings for the variables.

Timestamps:

Start: Set when one of the device variables is put into simulation mode

Stop: Set when all of the devices variables are put into normal mode

HART DD Menu Tree

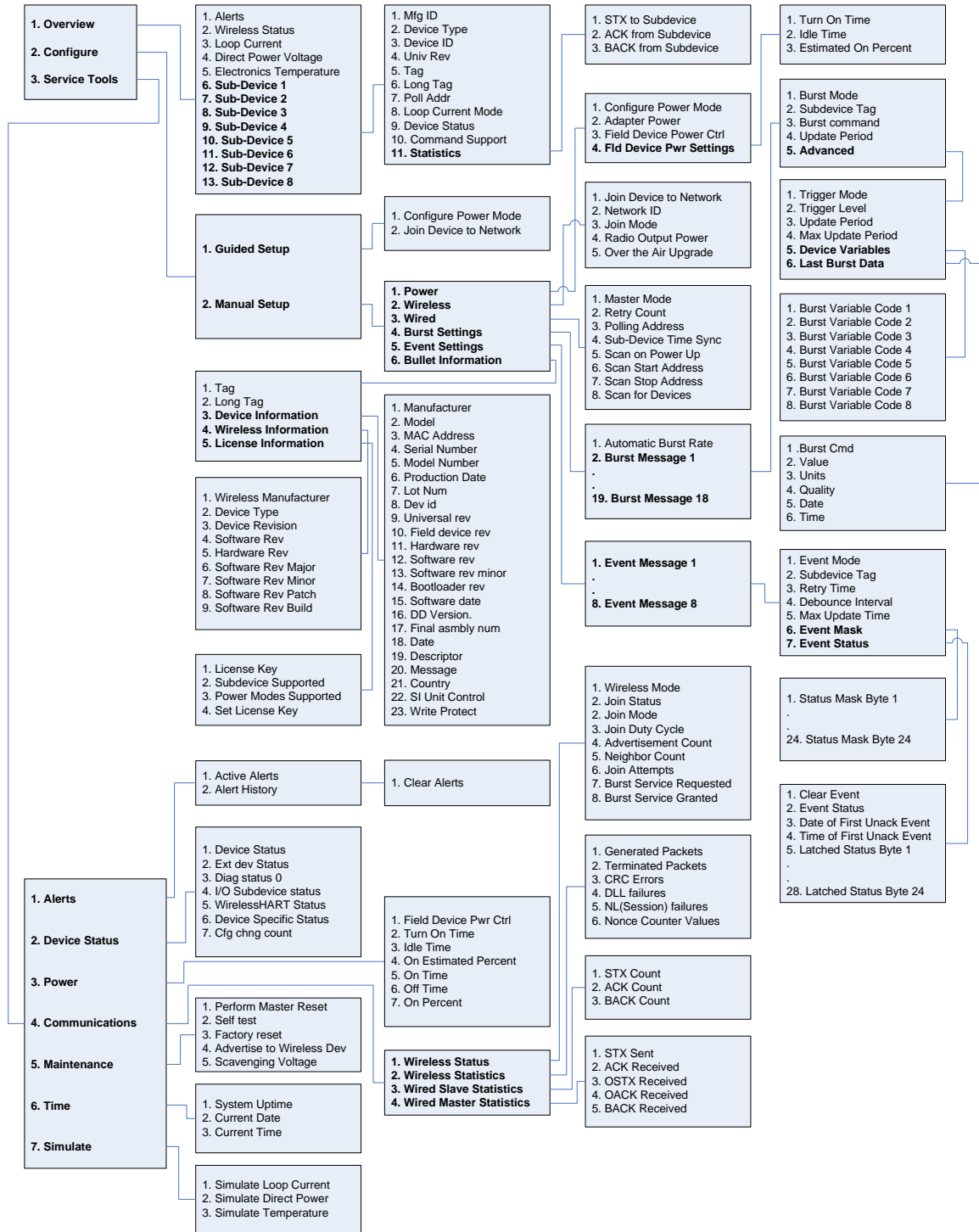

3. Installation

The Bullet was designed to be extremely flexible and support a variety of installation options.

Wire Color	Description
Green / Yellow	Internal Earth Ground
Black	Direct Power
Red	Loop Power
White	Return
Yellow	HART
Ground Screw	External Earth Ground

Antenna Positioning

The Bullet has an internal antenna which radiates out from top cap in a 360° pattern. The Bullet should be positioned vertically and located approximately 1 meter from any metal or conductive material which could impact the WirelessHART® communications. The operating range can be reduced by interference from other nearby devices transmitting in the 2.4 GHz ISM band. These external sources of interference can prevent the establishment of WirelessHART connection and may result in intermittent loss of network connections causing HART network message retries



The Bullet can be placed anywhere on the current loop and does not need to be positioned directly next to the field device. This allows positioning the Bullet in an optimal location for RF coverage.

Typical Installation

Listed below are several installation options for using the Bullet with or without HART devices. Please contact MACTek if you need help in determining how best to connect the Bullet for your application.

WARNING: An electrically conductive thread lubricant is recommended to be applied to the Bullet's NPT threads prior to assembly to minimize the potential of aluminum galling.

Bullet as a Standalone WirelessHART Router

The Bullet is not attached to any devices at all. It is strictly used at key points in a WirelessHART network to help with the WirelessHART routing of packets on behalf of other devices. This is useful when it is identified in a WirelessHART network that additional WirelessHART devices located at key points will improve the overall network robustness.

In this scenario, power will typically be supplied by direct power, however loop powered operation is possible.

For direct powered operation, connect the DC power supply positive terminal to the Black wire from the Bullet, and the negative terminal to the White wire.

Note: When used in loop powered mode, The Bullet cannot control the loop current. It is up to the user to ensure that the loop current is limited to within the operating specifications.

Bullet with a 4-20mA Analog Transmitter (non-HART)

The Bullet is connected in series with 4-20mA analog only transmitter which does not support HART. The Bullet is capable of monitoring and reporting the analog loop current to the WirelessHART network.

Connect the Bullet and transmitter as shown in either Figure 1: Configuration #1 or Figure 2: Configuration #2 drawings.

Bullet with a 4-20mA HART Transmitter

The Bullet is connected in series with 4-20mA HART transmitter which also controls the loop current. The Bullet is capable of monitoring and reporting the analog loop current to the WirelessHART network and will also communicate wired-HART data with the connected wired-HART sub-device.

Connect the Bullet and transmitter as shown in either Figure 1: Configuration #1 or Figure 2: Configuration #2 drawings.

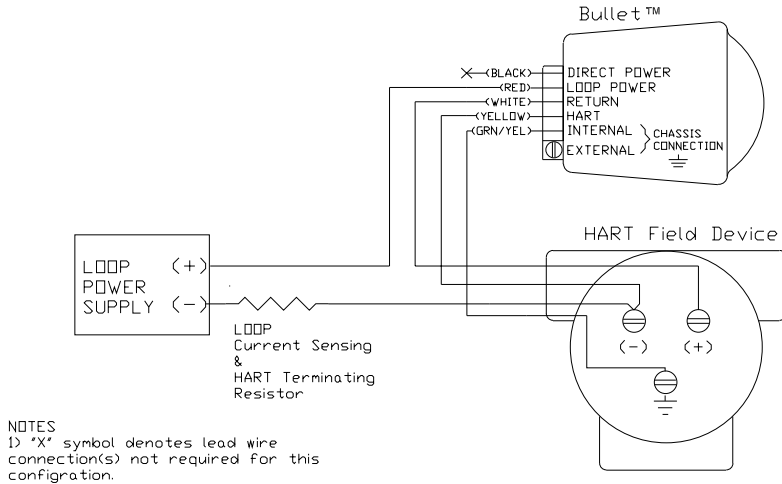

FIGURE 1: Configuration #1

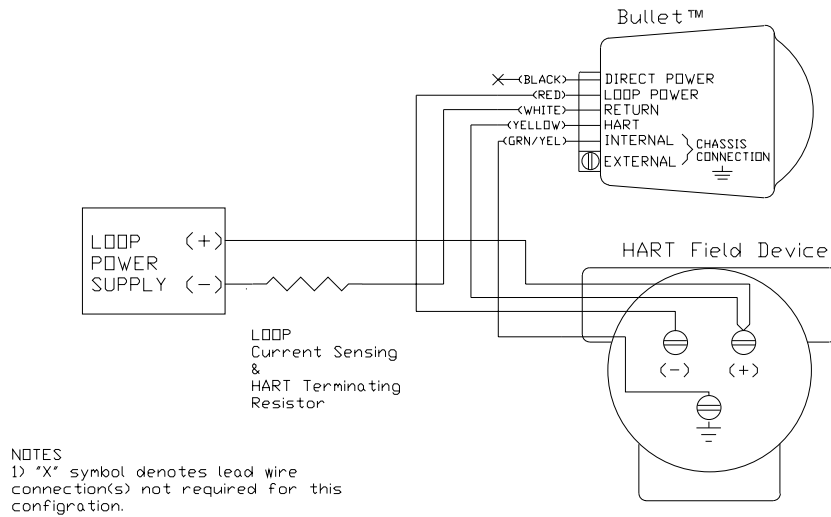

FIGURE 2: Configuration #2

Bullet with HART Devices in Multi-Drop Mode

The Bullet can support up to eight (8) wired-HART sub-devices. The maximum number of wired-HART sub-devices that any loop can support is installation dependent.

In this scenario, the Bullet is connected in a HART multi-drop mode, and can support communication with up to eight (8) wired-HART sub-devices. In Multi-drop mode the Bullet can be configured for either LOOP POWER or DIRECT POWER. For proper HART communication the Wired-HART sub-device requires a HART network terminating resistor. When configured for LOOP POWER, the terminating resistor must be hard wired into the system. When configured for DIRECT POWER, the terminating resistor requirement can be met by either physically wiring a resistor into the system or by using the Bullet internal terminating resistor.

The Bullet provides a switchable resistor connecting a 250 Ohm resistor between the HART and RETURN lead wires. To use the Bullet internal resistor the operator must properly configure the Device Description (DD). The operator must configure the DD parameter FIELD DEVICE POWER CONTROL to the – ON setting. Refer to section 2 Configuration, Detailed Setting, Field Device Power Control section for the description and use of the Device Description and required operator setting.

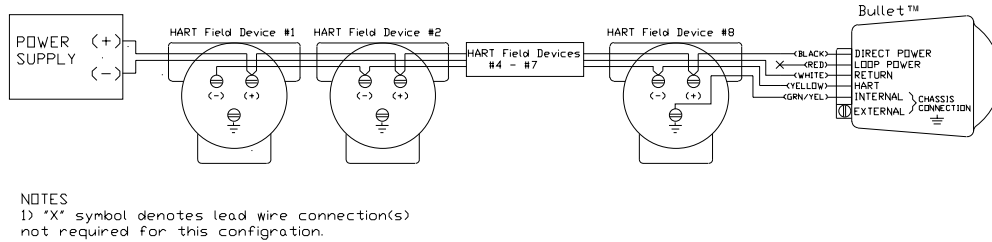

Figure 1: Multi-Drop Configuration

Bullet with a 4-20mA Transmitter with Battery Powered Operation

The Bullet is connected in series with a 4-20mA Transmitter, which can be analog only or HART capable. An external battery or other power source (such as solar) is used to power the system. The Bullet will duty-cycle power to the Transmitter to conserve power.

Bullet installation to Field Device

The Bullet typical installation to a field device is shown Figure 4. The Bullet is attached to the field device using the appropriate rated hardware as defined by the area classification of the installation.

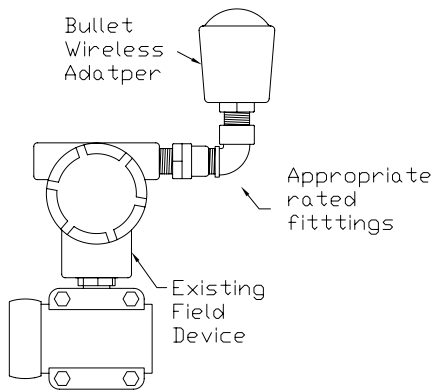

Figure 2: Typical Installation

4. Commissioning

Upon power-up of the Bullet in the field, the Bullet will attempt to identify any connected HART devices (if the Automatic Sub-device Detection option is enabled).

Operation can be verified through the use of the Bullet HART DD via a HART communicator or PC with HART Modem. Operation can also be verified via the WirelessHART Gateway interface.

With the DD, verify that the correct HART sub-device(s) have been detected by the Bullet. Also verify that the Bullet is attempting to join or has joined the WirelessHART Network.

With the WirelessHART Gateway, verify that the Bullet has been detected and that all of the connected wired-HART sub-devices have been detected.

NOTE: The Bullet should be installed after the WirelessHART gateway has been installed and is verified to be working.

NOTE: To speed the WirelessHART joining procedure, it is recommended to turn on the Active Advertising mode of the WirelessHART Gateway whenever new devices are added.

5. Troubleshooting

Does Not Detect Wired-HART Sub-Devices

Verify the Bullet wiring for the mode of operation that is being used.

Verify HART communication with the Bullet with a HART Communicator or PC with HART modem. Once this is working, without moving the HART connections on the modem, verify HART operation with the HART sub-device.

If the HART Communicator is able to communicate with both the sub-device and the Bullet, the Bullet should be able to communicate with the sub-device.

Cannot Connect to the WirelessHART Network

Check the WirelessHART Gateway for the correct Network ID and Network Join Keys.

Using the Bullet HART DD, both of these settings are entered in with a decimal format. It is possible that either of these settings are shown in a hexadecimal format on the WirelessHART Gateway. If so, convert these values into a decimal format before entering them into the Bullet.

Resetting the Bullet

Soft Reset – Via DD

Through the DD, a reset command can be performed to reset the Bullet.

Soft Reset – Via Power connections

Disconnect all power sources to the Bullet for 5 seconds. Reapply power and the Bullet reset

Hard Reset

Since the Bullet has a large internal energy store, to perform a true Hard Reset (complete power loss), disconnect all power sources to the Bullet for 5 minutes. Then re-apply power to the Bullet.

6. Certificates and Approvals

Telecommunication Compliance

FCC and IC

The device complies with FCC 47 CFR, Part 15 rules. Operation is subject to the two following conditions: (1) this device may not cause harmful interference and (2) this device must accept any interference received, including interference that may cause undesirable operation.

To ensure FCC & IC compliance, this device is to be used as configured from the factory. No modifications to either the radio or antenna are allowed.

European Union Directives

The EC declaration of conformity statement for all applicable directive(s) for this device can be found at the MACTek web site: www.mactekcorp.com

This device conforms to the requirements of the following directives
Radio and Telecommunications Terminal Equipment (R&TTE: 1999/95/EC)

Appendix A. Technical Specification

System	
Platform	WirelessHART capable network
Compliance	Fully compliant HART 7.1 device, complies with HART 7.1 Wireless Adapter device type. Backward compatible to HART 5 devices
HART Sub-Devices	Supports up to 8 wired HART sub-devices (maximum number depends on installation)
RF	
Range	235 meters outdoors, open air (nominal)
Operating Frequency	2.4GHz
RF Output Power	10dBm
Electrical	
Series Loop Voltage Drop	1.0VDC – 2.5VDC, user settable in 0.5VDC steps.
Series Loop Operating Current	3.2 ma to 25 mA DC operating; Protected against overvoltage, over-current, and reverse connections.
Ext Power Operating Voltage	+7VDC to +32VDC, Reverse voltage protection
Ext Power Operating Current	Typical < 1mA, Max: 20 mA
HART Output Level	Fully HART compliant trapezoidal wave @ 1200/2200 Hz
Multi-Drop (Direct Power)	32mA DC maximum, 8 devices at 4mA DC
Multi-Drop (Loop Power)	24mA DC maximum, 6 devices at 4mA DC
Loop Current Monitoring	3.2mA to 22mA DC
Environmental	
Operating Temperature	-40° C to +80°C: Temperature Class T4 ; -40°C to TBD T5: T6
Hazardous Location	
General Purpose	-40C° to +85°C
Humidity: relative	100%
Storage Temperature	-40° to +85°C
Physical Dimensions	
Dimensions	Height : 100 mm (3.9") , Diameter : 60.8 mm (2.4") , Weight : 0.46 kg (1lbs)
Enclosure	Housing: Metal, aluminum alloy, powder coated surface. Dome: propriety resin
Connection	One, Male ½" NPT with internal poured seal
Field Termination	5 lead wires x 600mm (24") long, exiting from male ½" NPT opening 5 leads: 4 signal and 1 internal earth grounding connection Enclosure: 1 external earth grounding screw
Certifications Obtained	
RADIO / EMC	FCC Part 15, IC, R&TTE
Rohs(2002/95/EC)	Restricted materials not used
Certifications Sought	
US / CANADA DIVISIONS	Explosion Proof, Intrinsically Safe Class I, Division 1 GROUPS A, B, C & D, Class II & III, Division 1 GROUPS E, F & G Non-incendive Class1 - Division 2 GROUPS A,B,C,D
US ZONES	Class I Zone 0,1 AEx 1/2 G ia d IIC Class I Zone 2 AEx nA IIC Class I Zone 20/21 AEx iaD 20 tD 21
CANADA ZONES	Class I, Zone 0,1 Ex 1/2 G ia d IIC Class I, Zone 2 Ex nA IIC Class I Zone 20/21 Ex 12 iaD A20 tD 21
CENLEC	Ex 1/2 GD EEx ia d IIC , Ex 3G EEx nA IIC , EEx iaD A20 tD A21
IEC	Ex 1/2 GD Ex ia d IIC , Ex 3G Ex nA IIC , Ex iaD A20 tD A21
Enclosure Ratings	IP68 , NEMA 4X